

INFORMATION FOR LIMITED DISTRIBUTION



Technical Bulletin

Ref: **TB-16001-ENG**

Issue date: **December 2017**

Product: INOmax DS_{IR}[®] Plus MRI

Priority: Low

Affected Parts: INOMAX[®] Cylinder, Cart Auto-Brake and Transport Regulator/Cap Assembly

Classification: Information for Limited Distribution

Subject: **MRI User Updates**

WARNING:

Only use a size "88" (1,963 liters) cylinder that is marked "MR Conditional". Keep cylinder at 100 gauss or less." Use of any other cylinder may create a projectile hazard.

INOMAX cylinder valve cap and INOmeter lock

Each INOMAX cylinder is shipped with a red plastic INOmeter lock (1) which prevents the INOmeter from moving during shipping, and a metal cylinder valve outlet cap (2), which protects the valve outlet (see Figure #1). The INOmeter lock and cylinder valve outlet cap are attached to a metal locking snap ring (3) using a vinyl coated wire (4) and chain (5).

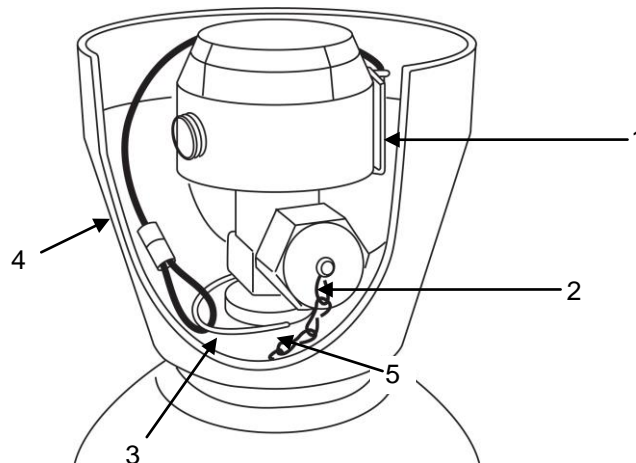

Figure #1

Caution: The cylinder valve cap, vinyl coated wire, metal locking snap ring and chain contain ferromagnetic materials and may represent a projectile hazard if not properly attached. When the INOmax DS_{IR} Plus MRI is used according to the manufacturer's instructions in areas where the magnetic field strength is less than 100 gauss, they do not present a projectile hazard. The metal locking snap ring may come loose when removing the cylinder valve tape and shrink film. The metal locking snap ring must be inspected to confirm attachment prior to entering the MR scanner room.

Complete the following steps on all INOMAX MR Conditional cylinders prior to entering the scanner room:

Step one:

Remove the tape and shrink film from the INOmeter and valve (see Figure #2).

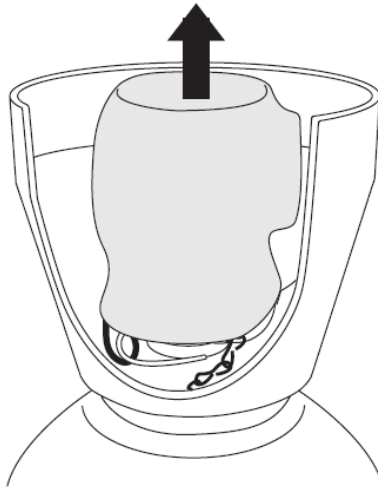

Figure #2

Step two:

Verify that the metal locking snap ring is latched and secured around the cylinder valve (see Figure #3). Reconnect and secure the metal locking snap ring if it is not properly latched or remove the ring assembly (see Figure #4) per hospital policy.

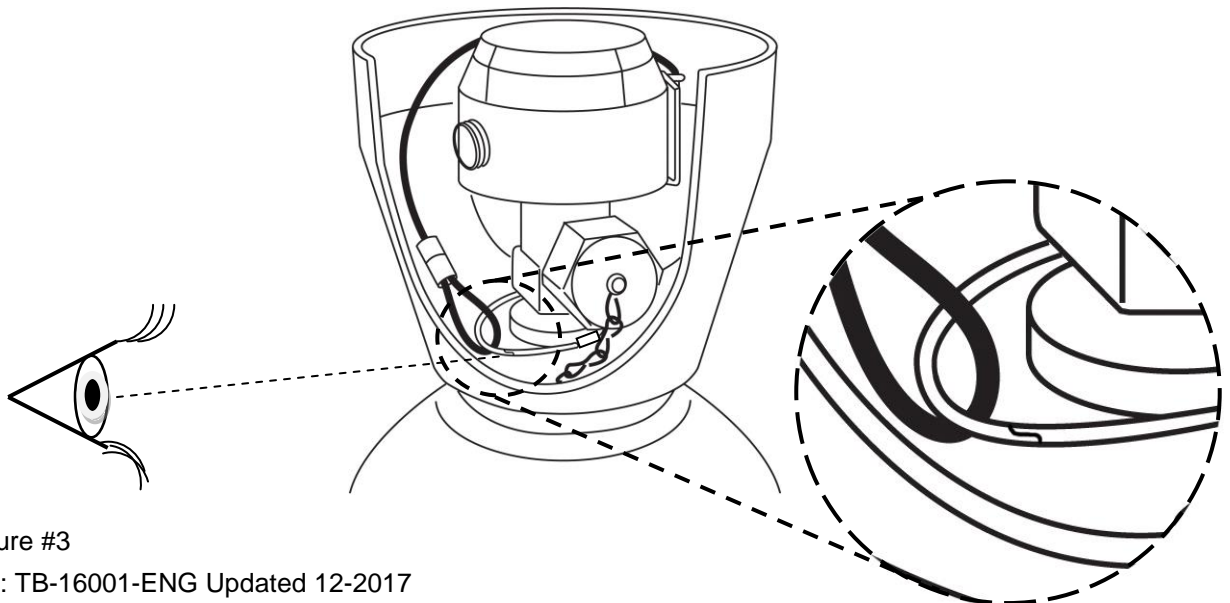

Figure #3

Ref: TB-16001-ENG Updated 12-2017
PN 20712, rev. 04

Do not dispose of the lock/valve cap assembly. If the metal locking snap ring and lock/valve cap assembly has been removed, reattach when the cylinder is returned to Mallinckrodt.

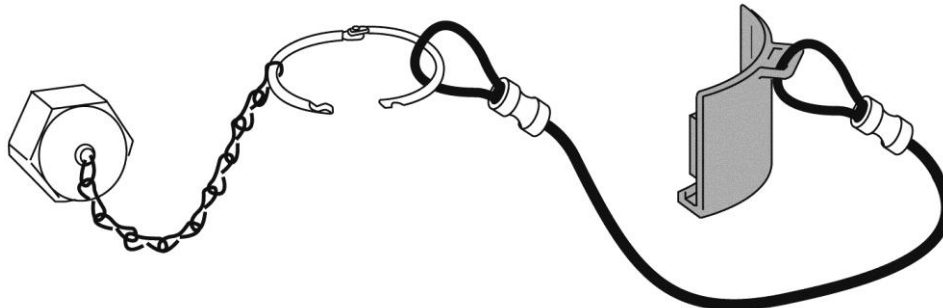

Figure #4

Testing the INOmax DS_{IR} Plus MRI Cart Auto-Brake

Pull up on the brake handle (see Figure #5), the INOmax DS_{IR} Plus MRI cart should move freely. While pulling the cart towards you, release the handle, the cart should stop or be difficult to move. If the cart continues to move freely when the brake handle is released, do not use the device and contact your local representative.

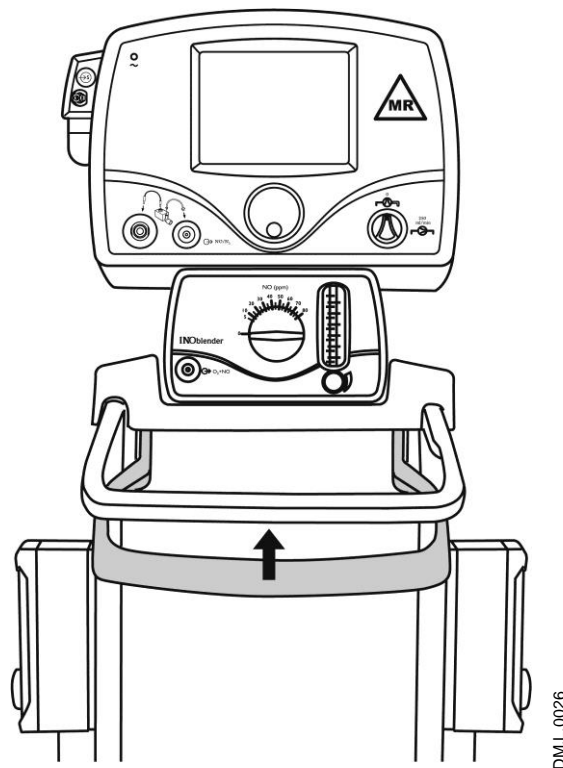

Figure #5

WARNING: If the cart moves freely when the brake handle is released, do not use the device.

Transport Regulator/Cap Assembly

Do not use the transport regulator/cap assembly in the MR scanner room.

Additional MR Scanner Room Testing

Images of a spherical phantom were quantitatively analyzed with geometric dimensions measured to assess artifact dimension change and signal-to-noise ratio.

Artifact Dimensional Analysis

Warning: The operation of the INOmax DS_{IR} Plus MRI system within an MR Environment can significantly influence the image quality.

These values were compared using scans that were conducted with and without the INOmax DS_{IR} Plus MRI system present in the MR scanner room.

Table below reflects maximum artifact dimension change with system plugged in and while on battery:

1.5T	The maximum dimensional change in images acquired during operation of the INOmax system is 0.8cm
3T	The maximum dimensional change in images acquired during operation of the INOmax system is 0.3cm

Signal-to-Noise Ratio (SNR) Analysis

System unplugged from AC outlet

Image Quality SNR Analysis	1.5T	The SNR change is -25% to +8% compared to images without the MR Conditional INOmax DS _{IR} Plus MRI system present
	3T	The SNR change is -18% to +23% compared to images without the MR Conditional INOmax DS _{IR} Plus MRI system present

System plugged into AC outlet

Image Quality SNR Analysis	1.5T	The SNR change is -60% to -18% compared to images without the MR Conditional INOmax DS _{IR} Plus MRI system present
	3T	The SNR change is -19% to +5% compared to images without the MR Conditional INOmax DS _{IR} Plus MRI system present

Note: If loss of SNR impacts image quality, it is recommended to power the INOmax DS_{IR} Plus MRI system with battery (system unplugged).

The operation of the INOmax DS_{IR} Plus MRI in the MR scanner room testing showed limited effects on the acquired image quality with respect to signal-to-noise ratio and geometric distortion when using sequences that are expected to be more susceptible to RF and gradient artifacts.

For technical assistance regarding the INOmax DS_{IR} Plus MRI, please contact technical support at 1-877-566-9466 (North America) or your specific country manager.

Mallinckrodt Manufacturing LLC
6603 Femrite Drive,
Madison, WI 53718-6801 USA

Mallinckrodt, the "M" brand mark and the Mallinckrodt Pharmaceuticals logo are trademark of a Mallinckrodt company. Other brands are trademarks of a Mallinckrodt company or their respective owner. ©2017 Mallinckrodt

Ref: TB-16001-ENG Updated 12-2017
PN 20712, rev. 04