

Connection to a Circle Anesthesia Ventilator System

IMPORTANT: This guide is provided as a convenience and for General Information only. Never use this product without clearly and thoroughly understanding the most recent revision of the INOmax DS and INOvent Operation Manuals. The Operation Manual is the source for specific, updated information regarding warnings, cautions, checklists, diagrams, and/or instructions contained in this guide.

**See set up diagram on the reverse side of this document
For assistance contact Technical Support 877-566-9466**

WARNING:

1. Avoid recirculation of gases. Un-desired recirculation of gases will occur if fresh gas flows are less than the patient minute volume and may result in:

- **Higher NO₂ levels due to the limited ability of the carbon dioxide absorbent to remove NO₂.**
- **Higher concentrations than those set due to NO recirculated through the absorber.**
- **Reduction in O₂ concentrations because nitrogen is the balance gas for nitric oxide and will be present in the recirculated gases.**

2. If the Injector Module was used in the wet/humidified part of the breathing circuit, it should be sterilized between each patient use.

Caution:

1. Note airflow direction on the Injector Module: the flow out of the absorber must pass through the Injector Module in the direction of the arrow on the module.
2. Nitrous oxide (N₂O) will affect the Set NO versus the measured NO value. For a 50% N₂O, 50% O₂ composition, the measured NO value will be approximately 7% indicated less than the same Set NO value of 100% O₂. For example, at a Set NO of 20 ppm, measured NO will be approximately 18 ppm.
3. Similarly, the effect of 2% v/v isoflurane will result in a high measured NO value of approximately 3% indicated for the same Set NO value at 100% O₂.
4. Sudden changes in anesthetic agent concentration may cause brief transient changes in the measured NO and NO₂ values.

Connection to a Circle Anesthesia Ventilator System

IMPORTANT: This guide is provided as a convenience and for General Information only. Never use this product without clearly and thoroughly understanding the most recent revision of the INOmax DS and INOvent Operation Manuals. The Operation Manual is the source for specific, updated information regarding warnings, cautions, checklists, diagrams, and/or instructions contained in this guide.

See applicable warnings and cautions on page 1 of this document.

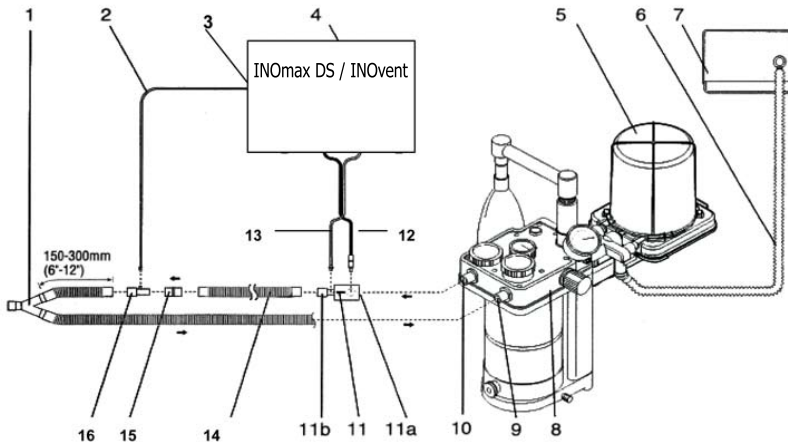

Note:

1. With a circle anesthesia breathing circuit, the INOmax DS / INOvent delivery system will perform as specified in the technical specifications with **fresh gas flow rates equal to or greater than the patient minute volume.**
2. The breathing circuit between the sample tee and the patient Y should be between 6 and 12 inches (150 -300mm) long: greater than 6 inches to minimize the sampling of mixed inspired/expired concentrations and less than 12 inches to help ensure correct NO₂ measurement.
3. For OR ventilation systems with the inspiratory flow measurements at the inspiratory port of the absorber, place the Injector Module upstream of the inspiratory flow sensor.

1. Patient wye
2. Gas sample line
3. Sample line inlet
4. INOmax DS / INOvent delivery system
5. Bellows assembly
6. Ventilator drive gas line
7. Ventilator (rear view)
8. Absorber
9. Absorber expiratory port
10. Absorber inspiratory port
11. Injector Module
 - A. input
 - B. output
12. Injector module cable
13. Injector module tubing
14. Inspiratory hose
15. 22M / 15F X 22M / 15F Adapter
16. Sample Tee

For assistance contact Technical Support 877-566-9466